

The EM CU BOX PRO combines a pre-wired emergency lighting driver and a battery in a plastic housing, allowing existing luminaires to be easily retrofitted for use as emergency lighting conforming to the European selftest standard. As the EM CU BOX PRO is compatible with all dimmable and non-dimmable LED drivers, neither a combo device nor a special driver is required. Thanks to a plug-in system and the option of loop-through wiring, installation can be completed in just a few steps. The LiFePO₄ battery technologies are supported and charged by microprocessor controlled cycles corresponding to the battery. A battery regeneration process of capacity optimisation is initiated automatically after commissioning as well as after each battery exchange.

Technical specifications

Mains voltage range:	220 – 240 V 50 / 60 Hz	Functionality test:	weekly 2 min.
Output voltage range:	20-105 V	Duration test:	Annually
Max. output voltage:	120 V	Battery charging time:	24 h
Output power in emergency mode:	3 W ±15 %	Protection classes:	I and II
Power consumption:	max. 3 W / 4,2 VA	Protection type:	IP20
Switchover time mains to emergency:	< 0,5 s	Weight:	560 g

Article

EM CU BOX PRO 105V TS 3W 1h

Art. Nr. 1389110530

Properties

- Non-maintained mode
- 1h emergency operation duration
- (Switched) Maintained mode in combination with an external LED driver
- Selftest conforming to IEC 62034
- Bus communication options available
- LED status display
- Compatible with all dimmable and non-dimmable LED drivers
- 5-pin technology: LED module changeover switching and delayed LED driver power switching
- Constant power output in emergency mode
- Specific charging currents and charging cycles corresponding with the respective battery technology (LiFePO₄)
- Deep discharge protection

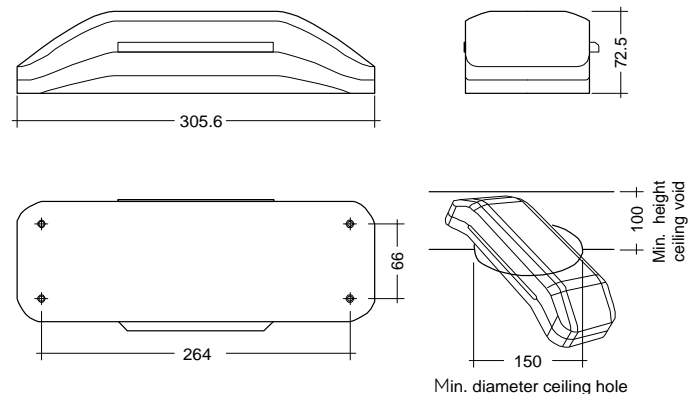

Product liability:

Please note that the maximum voltage in case of LED module failure may reach 60V. The requirement of the EN 60598-1 standard concerning security must be fulfilled after the integration of the emergency lighting unit in the LED luminaire. It is the emergency lighting unit's user's full responsibility to comply with the EN 60598-1 standard. Any liability concerning standards compliance and correct emergency lighting unit selection will be denied by the manufacturer.

Selftest

- Selftest conforming to IEC 62034
- Bi-colour LED status display
- Battery status
- LED module status
- Charging cycle



LED green: System fault free



LED red blinking: Mains available with battery not connected or faulty battery



LED red intermittend blinking: Light defect or not connected



LED off: Mains fault, Mains under 160 V, Battery fully discharged or faulty emergency unit

Batteries

- High-temperature cells 5 to 50 °C
- LiFePO₄ batteries
- 18650 cells
- Charging time 24 h
- 4 years expected life duration
- 12 months warranty
- Battery regeneration for capacity optimisation

Safety

- Protection classes I and II
- Protection type IP20

Standards

- EN 60598-2-22
- EN 61347-2-7
- EN 61347-2-13
- EN 62384
- EN 62034
- EN 55015
- EN 61000-3-2
- EN 61000-3-3
- EN 61547
- Suitable for systems conforming to: VDE 0108 or EN 50172

Certification marks

- CENELEC certificate (pending)
- CE

Connection diagram

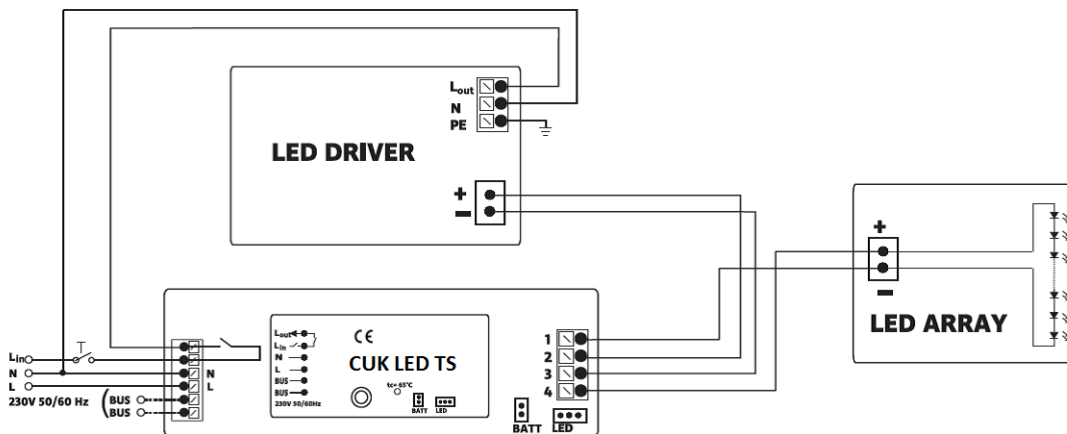

⊕ = reinforced insulation between LED-module and mains